

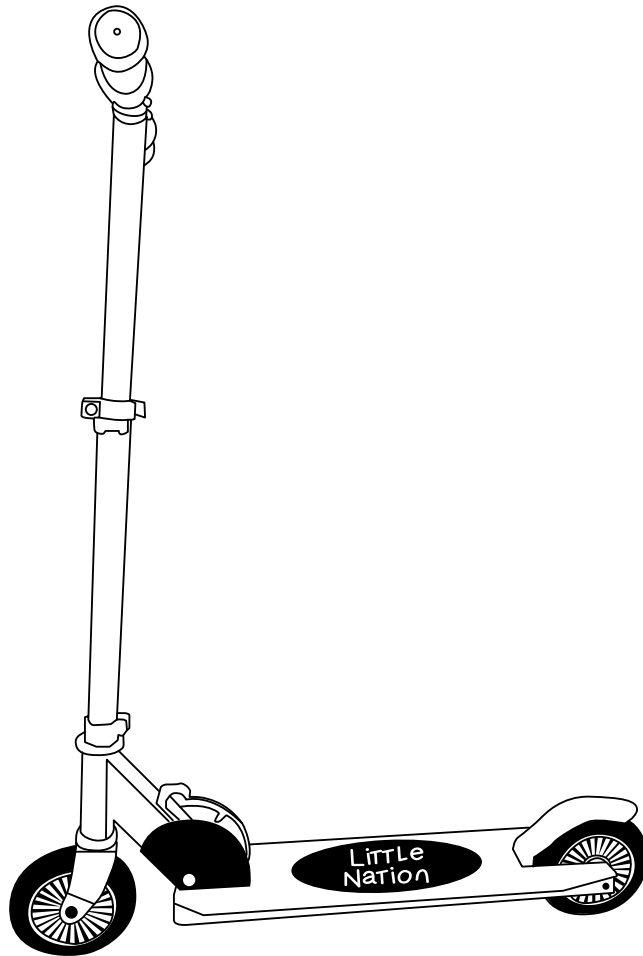

LITTLE NATION

2 WHEEL KIDS FOLDING SCOOTER



UK
CA



INSTRUCTION MANUAL

WARNING: Please read this Manual thoroughly before assembling, riding, or performing maintenance on this bicycle. Parental supervision is highly recommended when kids are using the bike. Always wear helmet and protective gears for protection and to avoid serious injury.

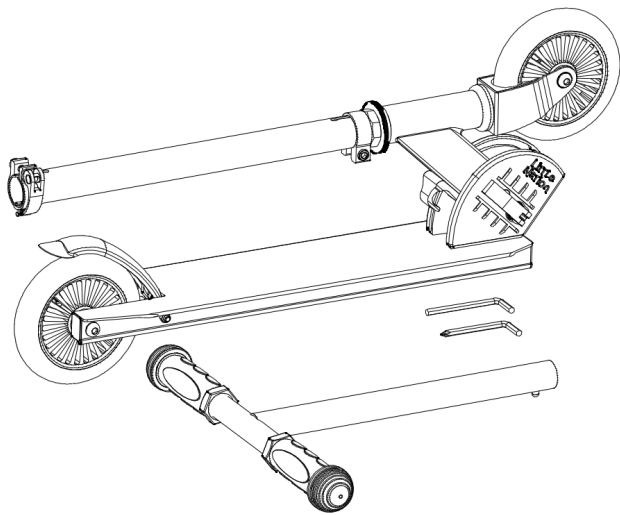

1

Package contents are as follows

- Scooter frame
- T-Bar
- 2pcs of Allen Key (1pc with screw driver)
- Instruction Manual

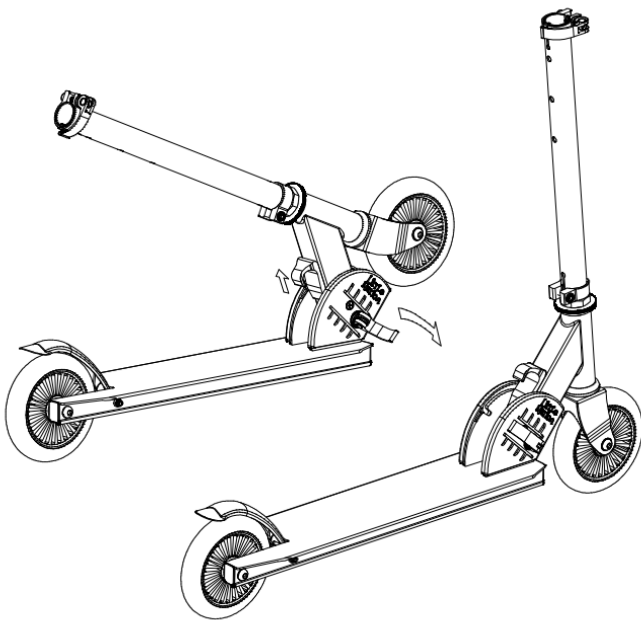

2

Open the locking lever and pull the release button to unfold the scooter frame, then close the locking lever as shown in the diagram.

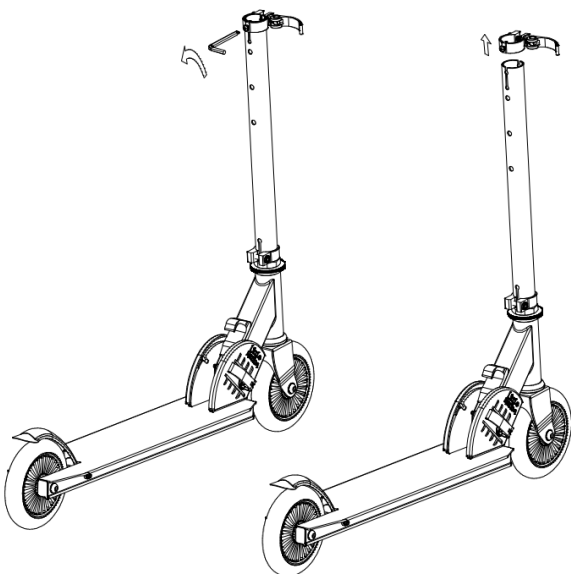

3

Loosen the screw and take out the Upper lock as shown in the diagram.

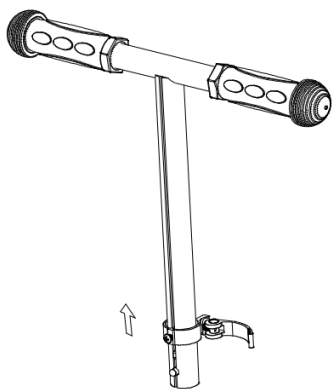

4

Assemble the upper lock on the T-bar.

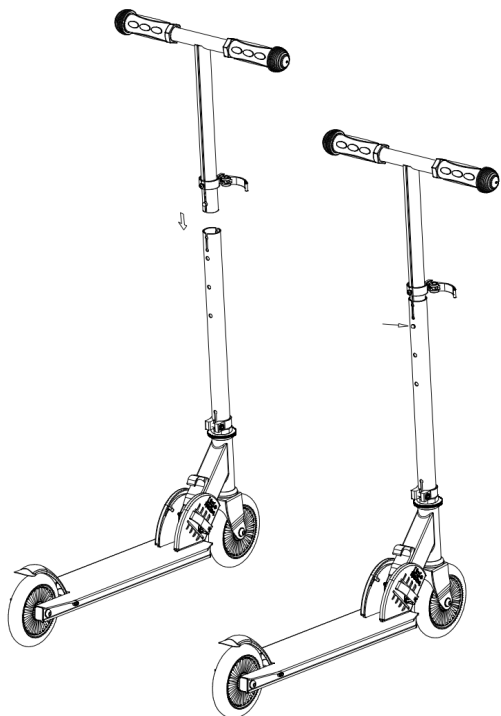

5

Insert the T-bar into front tube as shown in the diagram.

6

Press the button, adjust and click it into the preferred height hole.

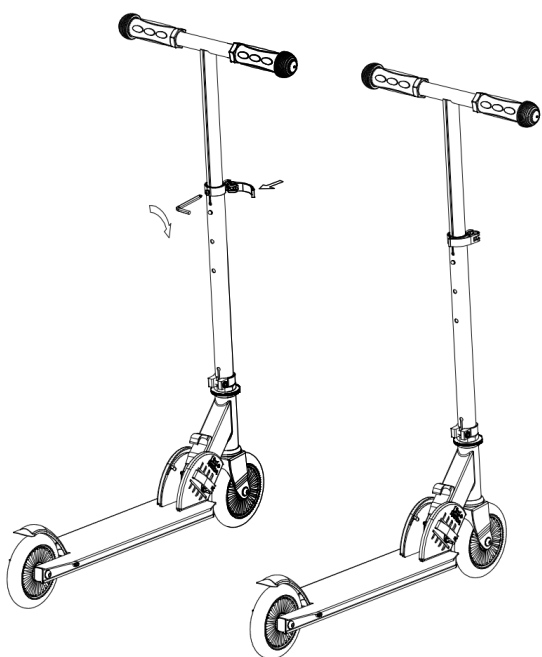

7

Assemble the lock on front tube, tighten the screw and close the upper lock. ENJOY the RIDE!